

Ka Band power detector

1. Features

Power Supplies: 0.8 V , 1.8 V
 Dynamic Range (+/-0.5 dB accuracy) :15 dB
 Input Differential Signal
 Single ended Output Voltage
 Maximum Input Power : 18 dBm
 Minimum Input Power : 3 dBm
 Power Consumption : 760 uW
 Settling Time (RF @ 10GHz) : 294 nsec
 Settling Time (RF @ 80GHz) : 470 nsec
 Silicon Area RF Part : 70 um x 75 um
 Silicon Area BB Part : 173 um x 120 um
 Process : 22FDX
 Metal Option : 19

2. Applications

5G,Radar,Satellite

3. Description

The WEAKA01PD22G is a power detector capable of detecting signals in the range of 3 dBm to 18 dBm with an accuracy of +/-0.5 dB. It produces a voltage proportional to the received signal power with the maximum output voltage being 1.1 V. It consists of 2 parts, the RF and the Analog processing part. Multiplexing can also be used to support multiple RF inputs with minimal impact on the silicon area using the same analog part. The detector is ideal for detecting the envelope of modulated signals in the frequency range from 10 GHz to 80 GHz.

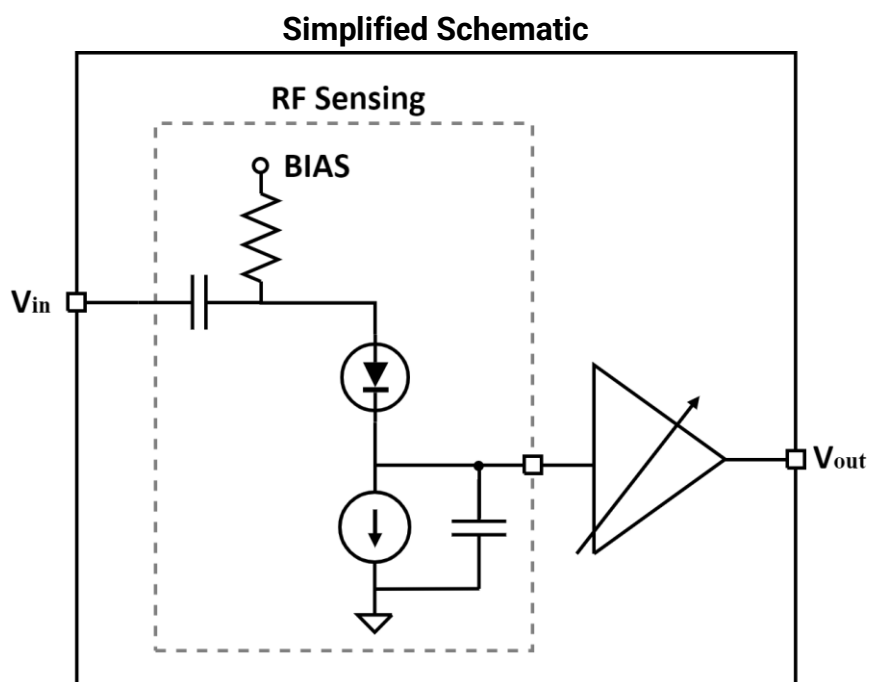

4. Pin Out Description

Pinout	Purpose	Description
vdd18	PS	Positive BB supply - 1.8V nominal
vss	GND	Power Ground
vdd08	PS	Positive RF supply - 0.8V nominal
pd	DI	Power Down pin
ibiasInP25u	AIO	Bias Const current 25 uA
rfa	I	RF input (diff sig)
rfb	I	RF input (diff sig)
vPowerSense	O	Power Sensor Output Voltage

(1) I=Input, O=Output, IO=Input,Output ,PS=Power Supply, DI= Digital Input, AIO=Analog Input Output

5. Availability

GF 22FDX, Metal Option 19





6. Deliverables

GDSII, Database, SystemVerilog Models

About weasic

weasic Microelectronics S.A. designs, develops, and markets high quality complex analog and RF IP for wireless communications and wireless sensors applications, helping semiconductor and system companies to shrink the product design cycle. WEASIC, silicon verified IP is designed in the state of the art CMOS, CMOS-SOI and SiGe processes and can be easily ported and customized to serve the development of 5G and Backhaul communications transceivers, mmWave front-end modules, and RADAR sensors.

Contact us

-  1 Alamanas str., 15125 Marousi, Greece
-  +30 210 6100770
-  info@weasic.com
-  weasic.com